

Dynamic3Talk

Aluminium foldable monitor with integrated universal motorised lift system for “gooseneck” microphones

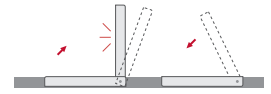

FEATURES

- Opens & folds down
- Adjustable & memorisable tilt angle
- Interactive setup display
- Compatible with “gooseneck” microphones
- Standard XLR-3pin connection
- Adjustable microphone length
- Dynamic Light LED ring indicated microphone status
- Easy to install
- Maintenance free
- HDCP compliant
- Energy saving design
- Dual safety system
- Serial control & Remote diagnose

GENERAL

Dynamic3Talk monitors have been designed for installation into tables or desks. Dynamic3Talk is a multi-position motorised monitor including an independent lift of “gooseneck” type microphones to be easily integrated into board, meeting and conference tables as well as into information counters; a smart combination of design, technology and ergonomics. It is a unique system for furniture integration, totally built in aluminium and glass. The screen opens and closes with a motorised movement similar to a laptop.

The back of the monitor housing can be covered with leather, wood, or any type of material to obtain a uniform finish of the table surface. The Dynamic3 product range provides keyboard, mouse and multi-touch screen as options. When the screen is moving up, a tray is automatically raised and the microphone has an independent mechanism. Thus, the user can choose not only the position of the monitor but also the accessibility to the microphone.

TECHNICAL SPECIFICATIONS

Display

| | |
|------------------------------------|--|
| Size | FULL HD 18.5" TFT Active Matrix |
| Resolution | 1920 (h) x 1080(v) |
| Brightness | 400 cd/m2 |
| Contrast ratio | 1500:1 |
| Pixel | 0.213(h) x 0.2813(v) mm |
| Viewing angle | 85°/85° (u/d) / 85°/85° (l/r) |
| Viewing area | 408.96(h) x 230.04 (v) mm |
| LED backlight lifespan | 50.000 hrs |
| Response time | Tr+Tf =35ms |
| Temperature (operating/storage) | Operating 0°C – +40°C Storage -20°C – +60°C |

Materials

| | |
|-----------------------|--|
| Cabinet & Cover plate | Monitor surface in toughened glass with touch buttons and main housing in milled out of solid aluminium in an anodized surface finishing. DynamicTalk integrated. DynamicTalk is a universal motorised microphone lift system remotely controllable through RS 422 or GPI with a Dynamic LED Ring for "ready to talk" and "talk" indications |
|-----------------------|--|

Connectivity

| | |
|-----------------------|--|
| Input signal | DVI-I (1 input) – HDCP Compliant DVI-D (1 input) – HDCP Compliant |
| RJ45 CAT5 (with loop) | Addressable RS422 monitor control by AHnet protocol |
| GPI (SubD9) | Movements control |

DynamicTalk Control

| | |
|---------------------|--|
| Up/Down Control | Button on upper cover plate GPI contact closer RS-422 (RJ45 CAT 5) |
| Microphone control | Button on upper cover plate |
| Customized function | Button on upper cover plate |
| GPI/O | LEDs control and switch |

Electrical

| | |
|-------------------------|----------------------------|
| Two ext. power supplies | 100-240Vac, 47/63Hz, 12Vdc |
| Display consumption | 55W |
| DTalk consumption | 10W |

Mechanical

| | |
|----------------------|--|
| Dimensions | 677 x 459.7 x 604.25 mm [26.65"x19.1"x23.78"] |
| Weight | 22.6 Kg / 49.8 lbs |
| Shipping Dimensions: | |
| Weight | 23.6 Kg / 52 lbs |
| Shipping Box | 672 x 717 x 207 mm |

OPTIONS

- DynamicLoop
- DynamicShare
- Keyboard & mouse
- USB camera
- Composite video camera
- HD-SDI camera
- USB integrated on cover plate
- 2 USB integrated on cover plate
- USB power integrated on cover plate

- Customised cover plate with speaker, voting system, USB connector
- Prepared for underneath installation, cover plate prepared to be veneered
- Additional Customised laser engraved logotype on the cover plate
- Monitor housing anodised in different colours
- Custom microphone connection

CERTIFICATIONS

- CE

WARRANTY

- 2 years general warranty

CONNECTIVITY PANEL

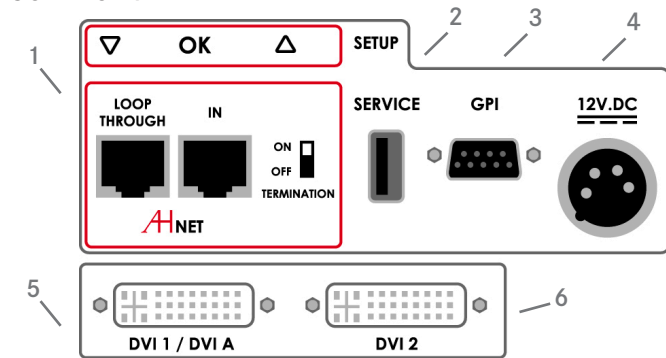

CONNECTIVITY

- 1- AHnet control interface
- 2- USB for Service
- 3- GPI control
- 4- Power input
- 5- DVI 1 / DVI A video input
- 6- DVI 2 video input

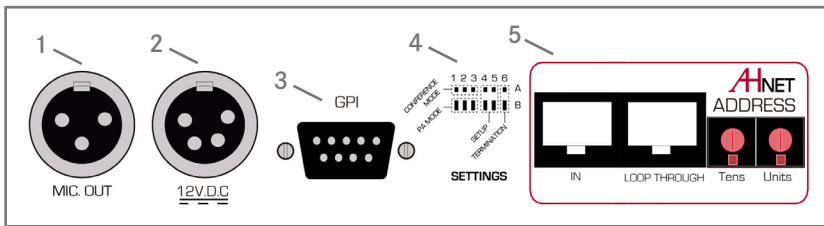

DYNAMIC TALK CONNECTIVITY

- 1- Microphone output
- 2- Power input
- 3- GPI control
- 4- DynamicTalk configuration settings
- 5- AHnet control interface

INTERACTIVE SETUP DISPLAY

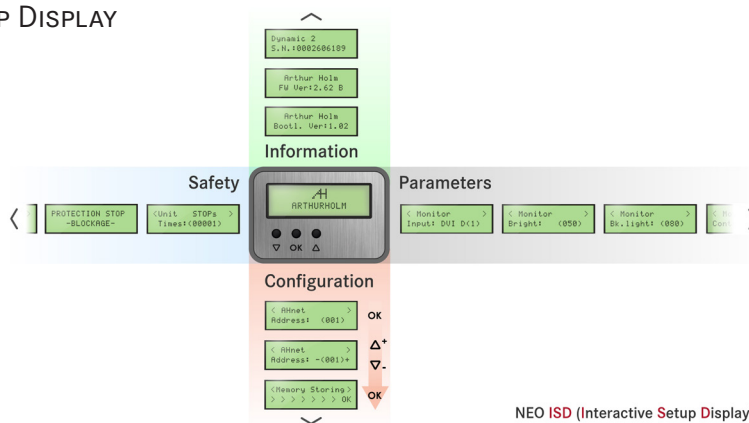

NEO ISD (Interactive Setup Display)

ARCHITECT'S SPECIFICATIONS

Motorised monitor with retractable microphone system, providing an integrated conference product. The screen and the microphone lifts can be operated independently.

Foldable FULL HD 18.5" widescreen motorised monitor. Screen housing milled out of solid aluminum in natural anodized finishing, with square corners design. Aluminum cover frame. Front black edged anti-reflective glass. Motorized folding movement. Can work in vertical position or with 20 degrees of inclination. Store position with the screen facing down with automatic screen switch-off system. DVI-I and DVI-D connectors. HDCP compliant inputs. Compatible with AHnet open protocol over RS-422, allowing independent remote control of up to 30 units over a daisy-chain CAT-5 or CAT-6 line. Additional control by means of the buttons integrated on the cover plate that can be activated or deactivated by using the AHnet. Easy to read Interactive Set-Up Display (ISD) 2,2"LCD display for address setup and status monitoring. Safety system that detects obstructions, stopping the unit. External power

supply with 4-Pin XLR4 connector. Rear connectivity. Total depth 604.25 mm for easier integration in the furniture. Adjustable mechanical parameters through AHnet or ISD for calibration and adjustment of mechanics. Diagnostic readout on ISD for increase service and support.

Low voltage professional retractable system for microphones up to 400/500/600mm long (upon request). Square brushed stainless steel cover plate integrated into the monitor's cover plate. Rounded microphone opening cover lid, and three buttons for system operation. Programmable green and red LED ring for microphone status indication. Design to avoid microphone damage or blockage when retracting. Operation modes for using standard microphones and conference systems. Compatible with AHnet open protocol, allowing independent remote control of up to 30 units over a daisy-chain CAT-5 line. Additional control by means of the buttons integrated on the cover plate and the general purpose interface inputs and outputs.

ARTHUR HOLM

Albiral Display Solutions SL. · Fàtima, 25 Sant Hipòlit de Voltregà 08512 Bcelona, Spain · +34 938 502 376 · marketing@arthurholm.com
www.arthurholm.com

Arthur Holm is a registered brand of Albiral Display Solutions SL. Specifications subject to change without previous notice.

GENERAL DIMENSIONS

AH19D3HDGATalk

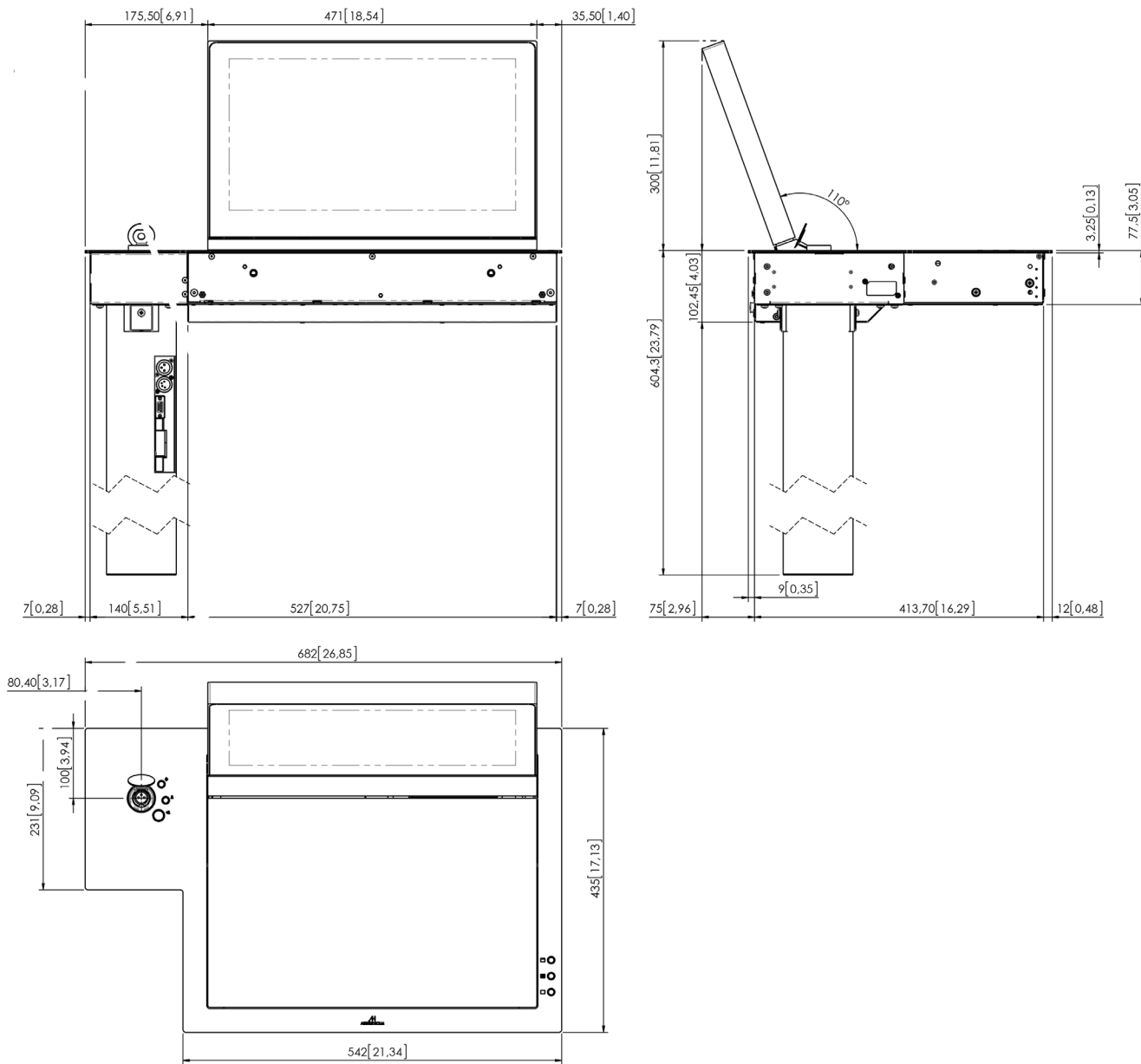

ARTHUR HOLM

Albiral Display Solutions SL · Fàtima, 25 Sant Hipòlit de Voltregà 08512 Bcelona, Spain · +34 938 502 376 · marketing@arthurholm.com
www.arthurholm.com

Arthur Holm is a registered brand of Albiral Display Solutions SL. Specifications subject to change without previous notice.